



Product Information

CE5-CADENZA • *CompactPCI*[®] Hostadapter Quad Serial ATA Controller & 2.5-Inch Hard Disk Drive

Document No. 3610 • Edition 2006-04

The **CE5-CADENZA** from **EKF** is a quad port Serial ATA hostadapter, compliant with SATA 1.0 specification. The CompactPCI board can be optionally equipped with an 2.5-inch on-board hard disk drive. Hence the CE5-CADENZA is a reliable mass-storage solution for rugged environments, suitable for any CompactPCI system.

The CE5-CADENZA provides an extended BIOS, which enables the module to operate either as boot device, or as additional SATA (RAID or non-RAID) host controller in a system.

In addition, the optional on-board SATA to Parallel ATA bridge allows for attachment of a legacy IDE (Parallel ATA) hard disk drive.



CE5-1H-CADENZA

Block Diagram CE5-CADENZA

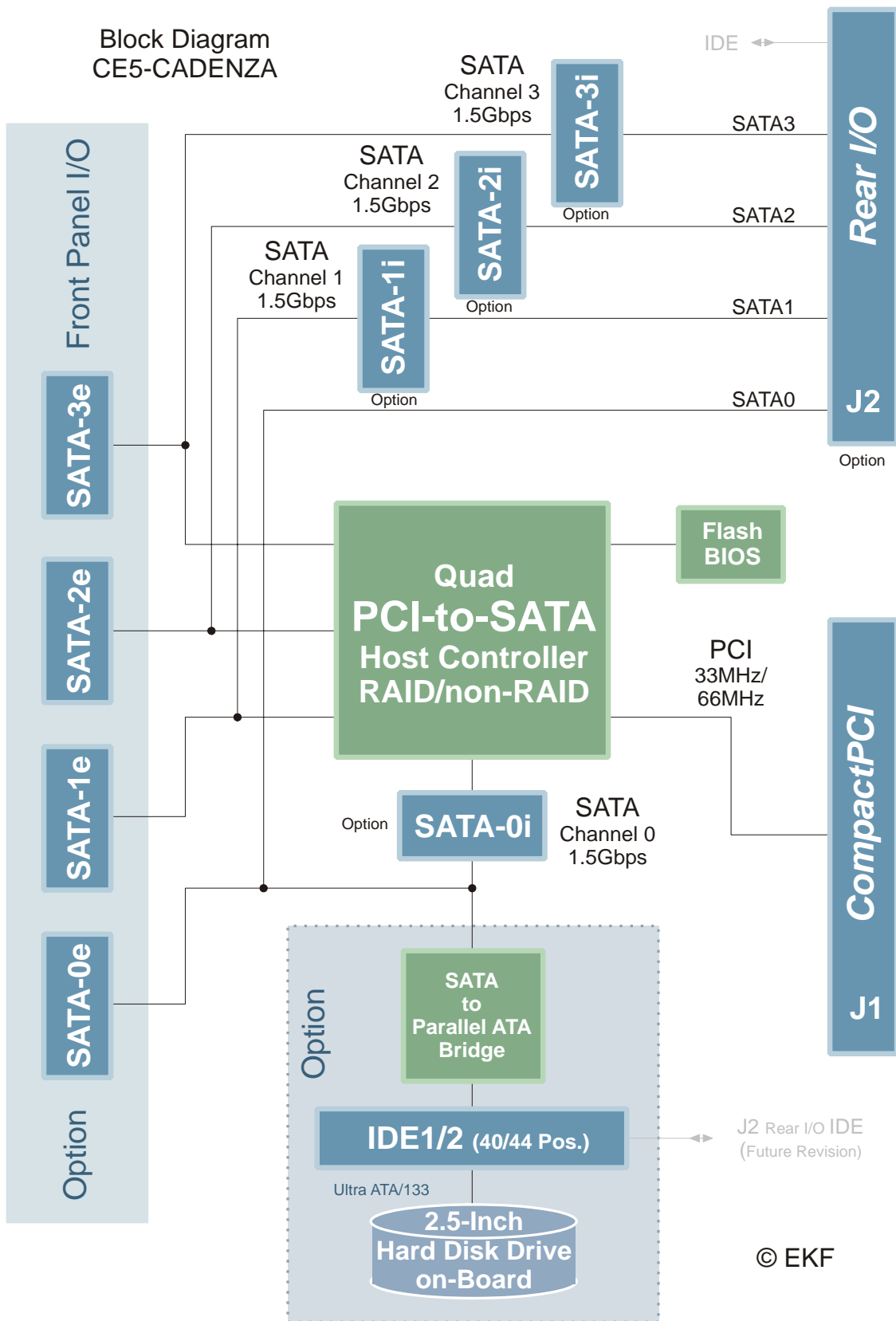

© EKF

The CE5-CADENZA provides four separate SATA channels to access storage media such as hard disk drive. On-board SATA connectors are provided optionally for system internal usage. As an alternative, SATA line 0 is dedicated to an optional on-board 2.5-inch hard disk drive by means of the on-board Serial ATA to Parallel ATA bridge. All SATA lines are alternatively accessible for external devices attached to the front panel connector.

Also available as an option, the SATA lines are alternatively wired for rear I/O usage across J2.

Available for download are drivers (RAID and non-RAID) for popular operating systems, e.g. Windows® 2000, Windows® XP, Linux and Netware. A software RAID configuration utility and a BIOS Flash tool complement the software suite.

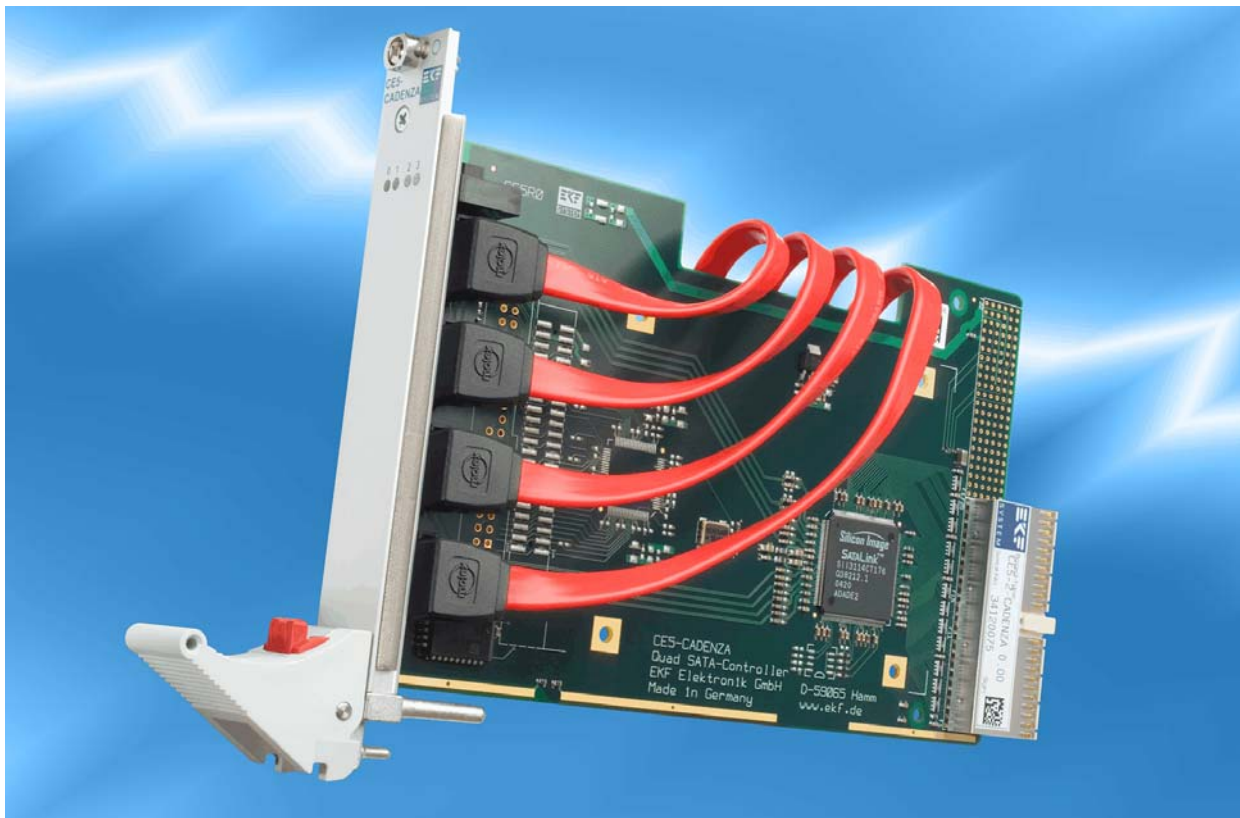

CE5-2-CADENZA

Feature Summary CE5-CADENZA

Form Factor	Single size 3U <i>CompactPCI</i> style Eurocard (160x100mm ²), front panel width 4HP (20.3mm)
Controller	PCI to quad-port Serial ATA (SATA) host controller (Silicon Image), SATALink 1.5Gbps
SATA Port Assignment (Connector Options)	<ul style="list-style-type: none"> ▶ Channel 0 available either via on-board connector option SATA-0I (I = system internal usage), or dedicated to the on-board SATA to Parallel ATA bridge (option for 2.5-inch IDE on-board hard disk drive), or available from the front panel optional connector SATA-0E (E = external usage), or optionally routed to CompactPCI connector J2 for rear I/O usage ▶ Channels 1-3 available either via on-board connector option SATA-1I ... SATA-3I (I=internal usage), or accessible via SATA-1E ... SATA-3E (E=external) front panel SATA connectors (option), or optionally routed to CompactPCI connector J2 for rear I/O usage
PCI Interface	32-bit, 33/66MHz, CompactPCI connector J1, 3.3V or 5V V _{IO} (not keyed)
BIOS	On-board Flash, non-RAID or RAID versions, programming tool available for BIOS update
Drivers/Software	Windows® 2000, Windows® XP, Linux and Novell Netware®, Software RAID (level 0 = striping , level 1 = mirroring, level 10 = mirrored stripe, level 5), RAID controller function requires changing of standard BIOS to RAID BIOS (BIOS Flash tool available by download)
Typical Power Consumption	+3.3V ±5% 0.45A max. +5V ±5% 0.75A max. (on-board hard disk only)
Thermal Conditions	<ul style="list-style-type: none"> • Operating temperature: 0°C ... 70°C (hard disk option: tbd) • Storage temperature: -40°C ... +85°C
Environmental Conditions	<ul style="list-style-type: none"> • Humidity 5% ... 95% non condensing • Altitude -300m ... +3000m • Shock 15g 0.33ms, 6g 6ms (hard disk option: tbd) • Vibration 1g 5-2000Hz (hard disk option: tbd)
MTBF	0.4 * 10 ⁶ h
Option on-Board Hard Disk Drive	2.5-Inch IDE hard disk drive, requires SATA to PATA bridge installed, 44-pos. connector 2.00mm pitch

[subject to technical changes](#)

Top View Assembly Drawing CE5-CADENZA

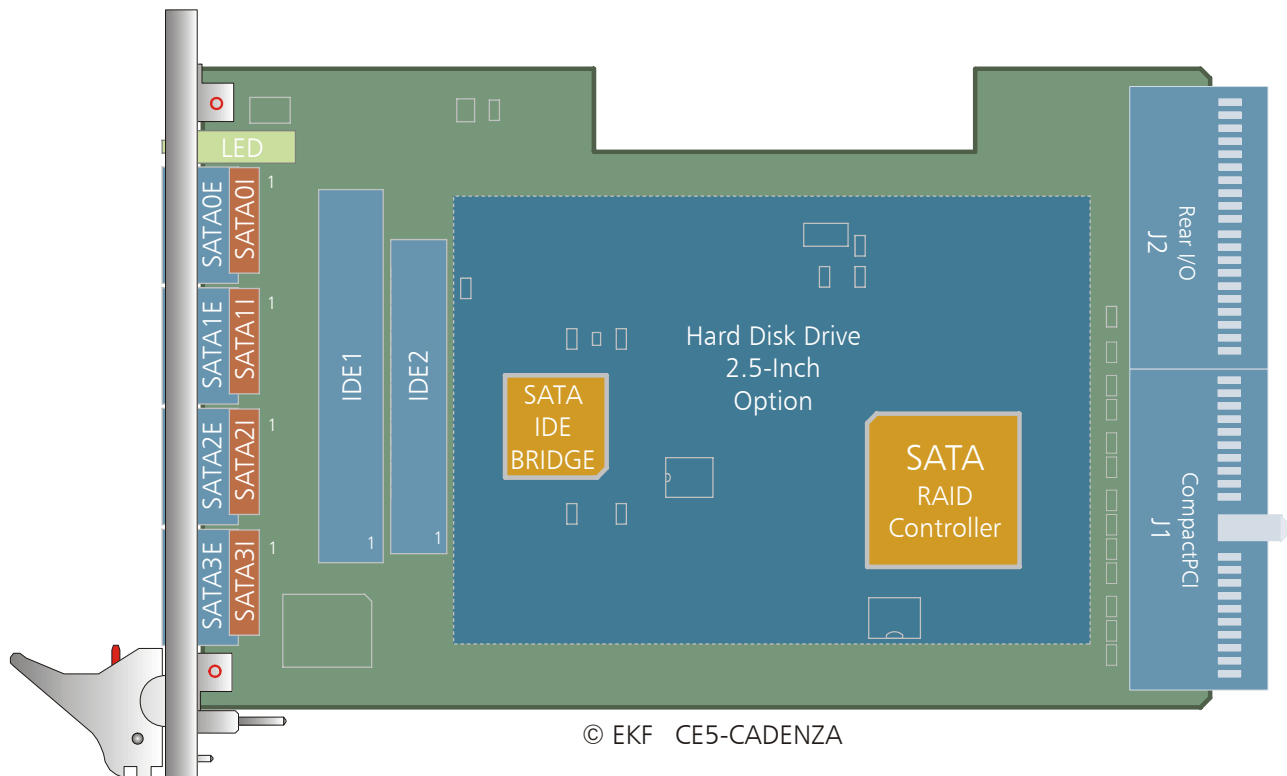

SATA Connectors SATA-0E ... SATA-3E (Front Panel Attached Devices)

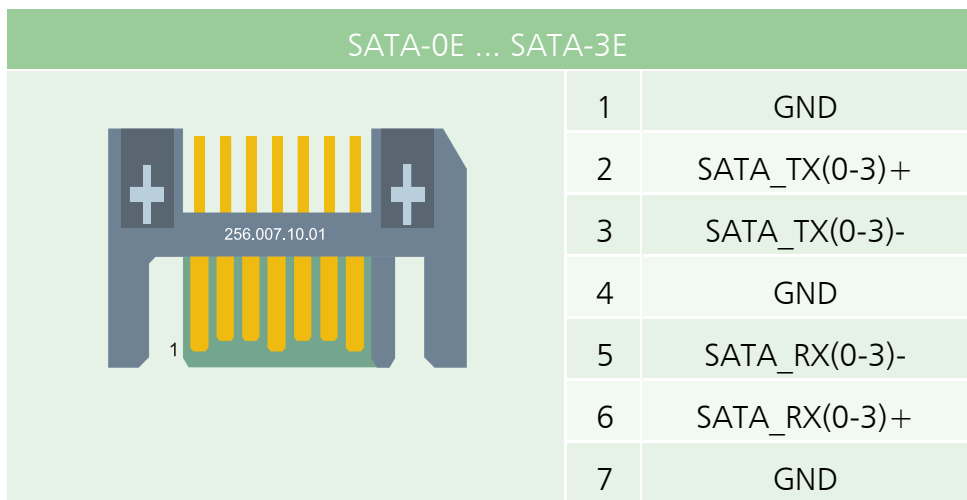

SATA Connectors SATA-0I ... SATA-3I (System Internal Usage)

SATA-0I ... SATA-3I		
	1	GND
	2	SATA_TX(0-3)+
	3	SATA_TX(0-3)-
	4	GND
	5	SATA_RX(0-3)-
	6	SATA_RX(0-3)+
	7	GND

When choosing a SATA cable assembly, a right angle SATA plug is recommended for attachment to the CE5-CADENZA internal receptacles SATA-xI in order to not exceed the boards 4HP height limit, e.g. Molex 88762-5400 (EKF 256.007.93.05).

The CE5-CADENZA is available in a number of custom specific configurations. All SATA connectors are provided as an option:

- ▶ Choose exclusively either SATA-0I (internal), or SATA-0E (external usage - front panel), or the on-board hard disk option, or the J2 rear I/O option
- ▶ Choose exclusively either SATA-1I (internal), or SATA-1E (external usage - front panel), or the J2 rear I/O option
- ▶ Choose exclusively either SATA-2I (internal), or SATA-2E (external usage - front panel), or the J2 rear I/O option
- ▶ Choose exclusively either SATA-3I (internal), or SATA-3E (external usage - front panel), or the J2 rear I/O option

Be sure to explore your individual requirements before ordering a custom specific version of the CE5-CADENZA. Choose an option for each individual SATA line. It is also valid to specify no function (not connected) for a particular SATA channel. Please request for a quote for your custom specific version (please include quantity).

Standard Versions	SATA Channel (Function/Connector)			
	Line 0	Line 1	Line 2	Line 3
CE5-1-CADENZA	SATA-0E	SATA-1E	SATA-2E	SATA-3E
CE5-1H-CADENZA	SATA/IDE Bridge	SATA-1E	SATA-2E	SATA-3E
CE5-2-CADENZA	SATA-0I	SATA-1I	SATA-2I	SATA-3I
CE5-2H-CADENZA	SATA/IDE Bridge	SATA-1I	SATA-2I	SATA-3I
CE5-3-CADENZA	J2 RIO	J2 RIO	J2 RIO	J2 RIO
CE5-3H-CADENZA	SATA/IDE Bridge	J2 RIO	J2 RIO	J2 RIO

Front Panel Options

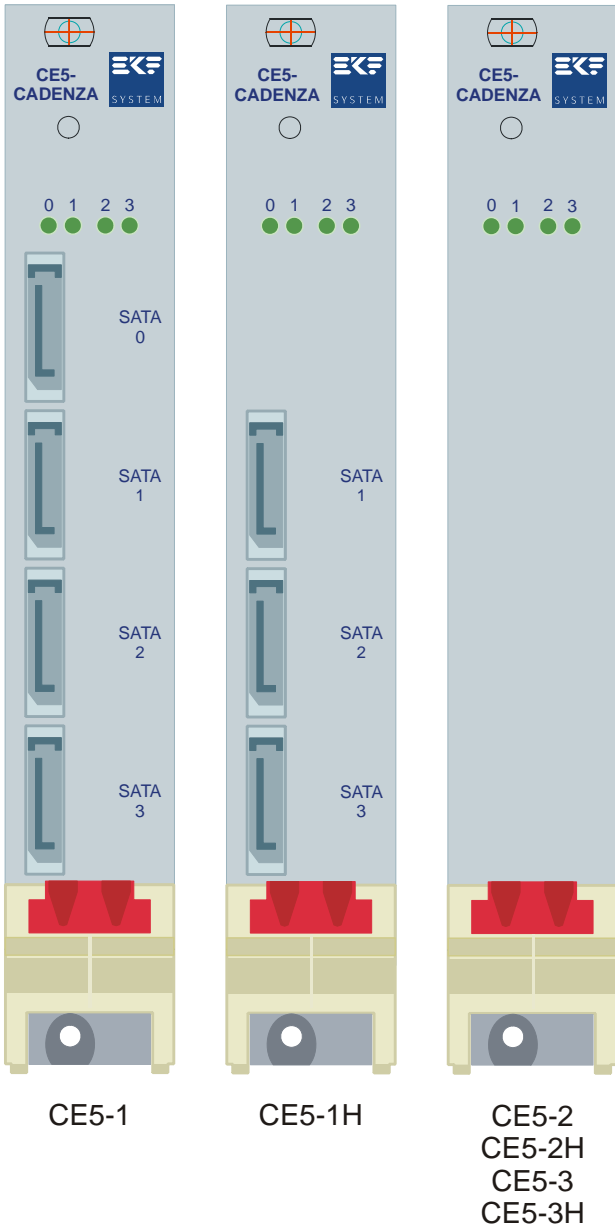

CompactPCI Connector J1

J1	A	B	C	D	E
25	5V	<i>REQ64#</i>	<i>ENUM#</i>	3.3V	5V
24	AD1	5V	VI/O	AD0	<i>ACK64#</i>
23	3.3V	AD4	AD3	5V	AD2
22	AD7	GND	3.3V	AD6	AD5
21	3.3V	AD9	AD8	M66EN	C/BE0#
20	AD12	GND	VI/O	AD11	AD10
19	3.3V	AD15	AD14	GND	AD13
18	SERR#	GND	3.3V	PAR	C/BE1#
17	3.3V	<i>SDONE</i>	<i>SBO#</i>	GND	PERR#
16	DEVSEL#	GND	VI/O	STOP#	<i>LOCK#</i>
15	3.3V	FRAME#	IRDY#	GND	TRDY#
14					
13			Not Keyed		
12					
11	AD18	AD17	AD16	GND	C/BE2#
10	AD21	GND	3.3V	AD20	AD19
9	C/BE3#	IDSEL	AD23	GND	AD22
8	AD26	GND	VI/O	AD25	AD24
7	AD30	AD29	AD28	GND	AD27
6	REQ#	GND	3.3V	CLK	AD31
5	<i>BRSVP1A5</i>	<i>BRSVP1B5</i>	RST#	GND	GNT#
4	<i>BRSVP1A4</i>	GND	VI/O	<i>INTP</i>	<i>INTS</i>
3	INTA#	<i>INTB#</i>	<i>INTC#</i>	5V	<i>INTD#</i>
2	<i>TCK</i>	5V	<i>TMS</i>	TDO ¹	TDI ¹
1	5V	-12V ²	<i>TRST#</i>	+12V ²	5V

gray/italic: NC

CompactPCI Connector J2 (Rear I/O Option)

J2	A	B	C	D	E
22	GA4	GA3	GA2	GA1	GA0
21	SATA_TX0-	SATA_TX0+	GND	SATA_RX0-	SATA_RX0+
20	ACTLED1#	GND	+5V	GND	ACTLED0#
19	SATA_TX1-	SATA_TX1+	GND	SATA_RX1-	SATA_RX1+
18	GND	GND	GND	GND	GND
17	SATA_TX2-	SATA_TX2+	GND	SATA_RX2-	SATA_RX2+
16	ACTLED3#	GND	+5V	GND	ACTLED2#
15	SATA_TX3-	SATA_TX3+	GND	SATA_RX3-	SATA_RX3+
14	GND	GND	GND	GND	GND
13					
12					
11	IDE_d08	GND	GND	IDE_reset#	IDE_d07
10	GND	IDE_d09	IDE_d10	GND	IDE_d06
9	IDE_d11	GND	GND	IDE_d04	IDE_d05
8	GND	IDE_d12	IDE_d13	GND	IDE_d03
7	IDE_d14	GND	GND	IDE_d01	IDE_d02
6	GND	IDE_d15	IDE_dmarq	GND	IDE_d00
5	IDE_dmack#	GND	GND	IDE_ior#	IDE_iow#
4	GND	IDE_a1	IDE_cblid#	GND	IDE_iordy
3	IDE_a2	GND	GND	IDE_a0	IDE_intrq
2	GND	IDE_cs1#	IDE_act#	GND	IDE_cs0#
1	+3.3V	+3.3V	+3.3V	+5V	+5V

gray: NC

Optional IDE Connector IDE1 (External ATA/ATAPI Devices)

IDE1 External IDE Device 2.54mm Dual Row Pin Header

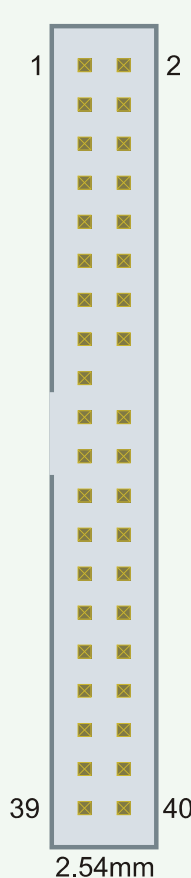

ide_reset#	1	2	GND
ide_d07	3	4	ide_d08
ide_d06	5	6	ide_d09
ide_d05	7	8	ide_d10
ide_d04	9	10	ide_d11
ide_d03	11	12	ide_d12
ide_d02	13	14	ide_d13
ide_d01	15	16	ide_d14
ide_d00	17	18	ide_d15
GND	19	20	KEY
ide_dmarq	21	22	GND
ide_diow#	23	24	GND
ide_dior#	25	26	GND
ide_iordy	27	28	GND
ide_dmack#	29	30	GND
ide_intrq	31	32	NC
ide_a1	33	34	ide_cblid#
ide_a0	35	36	ide_a2
ide_cs0#	37	38	ide_cs1#
ide0_act#	39	40	GND

Optional IDE Connector IDE2 (On-Board Disk Drive)

IDE2 On-Board 2.5-Inch Hard Disk Drive 2.00mm Pin Header 2x22

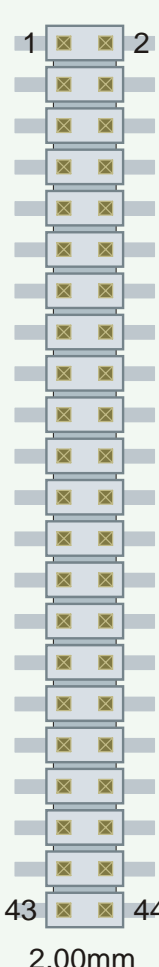
 <p>1 2</p> <p>43 44</p> <p>2.00mm</p>	ide_reset#	1	2	GND
	ide_d07	3	4	ide_d08
	ide_d06	5	6	ide_d09
	ide_d05	7	8	ide_d10
	ide_d04	9	10	ide_d11
	ide_d03	11	12	ide_d12
	ide_d02	13	14	ide_d13
	ide_d01	15	16	ide_d14
	ide_d00	17	18	ide_d15
	GND	19	20	KEY
	ide_dmarq	21	22	GND
	ide_diow#	23	24	GND
	ide_dior#	25	26	GND
	ide_iordy	27	28	GND
	ide_dmack#	29	30	GND
	ide_intrq	31	32	NC
	ide_a1	33	34	ide_cblid#
	ide_a0	35	36	ide_a2
	ide_cs0#	37	38	ide_cs1#
	ide0_act#	39	40	GND
	+5V_HD ¹⁾	41	42	+5V_HD ¹⁾
	GND	43	44	NC

1) PolySwitch 0.75A

Ordering Information		
Alias	Ordering No.	Short Description
CADENZA	CE5-1-CADENZA	3U CompactPCI Serial ATA controller, 4 SATA front panel connectors for external usage
CADENZA	CE5-1H-CADENZA	3U CompactPCI Serial ATA controller, 3 SATA front panel connectors for external attachment of devices, on-board SATA to IDE bridge, assembled with on-board IDE hard disk drive 2.5-inch
CADENZA	CE5-2-CADENZA	3U CompactPCI Serial ATA controller, 4 SATA on-board connectors for system internal usage
CADENZA	CE5-2H-CADENZA	3U CompactPCI Serial ATA controller, 3 SATA on-board connectors for internal attachment of devices, on-board SATA to IDE bridge, assembled with on-board IDE hard disk drive 2.5-inch
CADENZA	CE5-3-CADENZA	3U CompactPCI Serial ATA controller, 4 SATA channels routed across J2 connector for rear I/O usage
CADENZA	CE5-3H-CADENZA	3U CompactPCI Serial ATA controller, 3 SATA channels routed across J2 connector for rear I/O usage, on-board SATA to IDE bridge, assembled with on-board IDE hard disk drive 2.5-inch
ADAPT	CR9-5-ADAPT	Mechanical kit, expands 3U front panel to 6U
	256.007.92.05	Serial ATA (SATA) signal cable straight, 0.5m
	256.007.93.05	Serial ATA (SATA) straight to right angle signal cable, 0.5m



CE5-1-CADENZA



EKF Elektronik GmbH
Philipp-Reis-Str. 4
59065 HAMM
Germany



Fax. +49 (0)2381/6890-90
Tel. +49 (0)2381/6890-0
Internet www.ekf.com
E-Mail info@ekf.de